



# PRESENTATION & MAIN ACTIVITIES

# AeroSertec Group

AEROSERTEC  
group



6MM Euros in Annual Turnover

35% Aeronautic, 25% Defence, 20% Energy, 15% Space, 5% Other,



55 Professional Engineers

90-95% Specialized Engineers.



20+ Years of International Experience

Over 500 projects (TurnKey, OnSite-OffSite Services, Custom-made)

# TEAM

## SKILLED ENGINEERING TEAM:

Engineering of more than 20 years of achieved experience.

Engineers by specialities:

20 Design engineers

15 Stress engineers

15 System engineers

5 Software engineers

Average experience 8-15 years

Interfaces teams in customers facilities.

## MAIN LOCATION:



C\ Eric Kandel, Tecnogetafe,  
28906, Getafe (Madrid)  
TF: +34 91 724 17 75

[www.sertec.net](http://www.sertec.net)

C/ Early Ovington, 24 - Nave 4, Aeropolis  
41309 La Rinconada (Sevilla)

TF: +34 955 63 10 15

[www.aerosertec.com](http://www.aerosertec.com)

# AEROSERTEC

# PRESENCE



SPAIN (Madrid, Sevilla)

USA (Seattle, Miami)

CHILE (Santiago)



**AEROSERTEC**

# FACILITIES

Aerosertec-Sertec new facilities in Getafe (Madrid, Spain):

- Workshop Facilities: 750 m<sup>2</sup>
- Technical Office: 700 m<sup>2</sup>
- Located in business and technology park of Tecnogetafe.



**AEROSERTEC**

# CAPABILITIES

## ENGINEERING

- Structure & Systems
- Composite material developments
- Competencies coverage from design to in-service support
- Turn key packages with maximum responsibility
- Experienced teams able to develop full projects.
- Interfaces teams in customers facilities.

## TOOLING

- Turn key service. Concept, design, manufacturing, assembly, installation, commissioning & tune up support to customers.
- Highly automatized processes & assembly rigs.
- Trimming, drilling & countersinking automatic technology for composite.
- NDT processes & automatic tooling.
- US ECO Effect Test (no water involved).
- Autoclave, Hot Forming, RTM, VARTM, RFI and SMC one-shot processes for composites manufacturing.
- ATL, FTL processes for tooling development.

## TEST BENCHES

- Design, sizing and stress
- Manufacturing, assembly , commissioning and performance test
- Full scale Parts tests
- Certification & model validation
- System test rigs for Certification
- Vibration and Impact test
- Fatigue and Compatibility t
- Hydraulic system design and assembly
- Instrumentation: measurement parameters. experimental stress analysis (strain gages), surface preparation and bonding, calibration

## SIMULATORS

- Turn Key Projects of hardware and software of training simulators.
- Flight Simulators (fixed wings & rotatives).
- Driving Simulators (train, bus, special heavy machinery, heavy construction, port cranes...)
- Maintenance simulators (aircrafts, high automatized factories).
- Control post simulators (harbor control, aircraft control, train control, underground).
- Defense training: Ground vehicles, tanks and light vehicles for both driving & shooting positions. Artillery simulators, light weapon simulators.
- High technology, wide range of operations low-cost simulators.

## AIRCRAFT UPGRADES & PODS

- Installation kits
- Civil & military certifications
- Turnkey projects for POD's. Equipment and tests.
- Composite material development
- MRO projects
- Feasibility studies, engineering and manufacturing coverage.

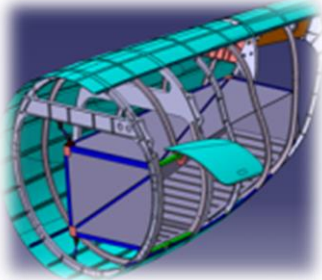

**AEROSERTEC**

# CAPABILITIES

## TRACKING SYSTEMS

- Turnkey Composite Tracking & Antennae Systems
- Passive Targeting & Antennae Systems
- Multiple Pan & Tilt Solutions



## SOFTWARE

- Turn key projects.
- Client based and R&D.
- Simulation, metrology, control systems, robotics, computer vision, 3D graphics modeling, simulation.
- Full product cycle: from design to implementation and maintenance.
- Metrology software and simulators.
- Industrial software
- Tracking technologies,
- AR,VR, CV



## AUTOMATION & REMOTE HANDLING

- Design and manufacturing remote handling systems for hazardous environments
- Robotic wing assembly system with high precision.
- Mobile Tool Platforms, Manipulators
- Nuclear industry hot cells decommissioning
- chemical and conventional munitions demilitarization
- Radioactive areas with X-Ray Inspection
- Caustic environments
- Explosive particulate and gases. Elevated temperature
- Underwater



## ROBOTICS

- Robotics supporting different aircraft equipment, with a robot perform various tasks such as placing ribs, tasks riveting or sealing.
- End Effectors tools interchangeable
- Sensitive clamp force
- Cameras and computer vision techniques
- RVE development in End Effector to reduce robot precision from  $\pm 0,05$  mm to  $\pm 0,02$  mm



## VISION SYSTEMS

- Mirror quality measurement inspection system. H.A.T.H.O.R.
- Computer vision
- Augmented vision
- Real scale demonstrations
- Riveting inspection
- Profile measurements
- 3D scanner

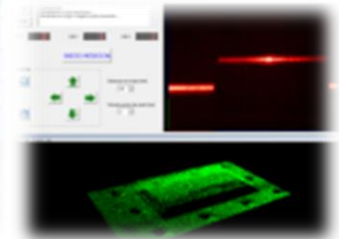

**AEROSERTEC**



# SECTORS

## AERONAUTIC

- A380
- A400M
- A350
- A350 Wing Lower Cover
- EADS-Eurofighter, Eurocopter-Tiger
- EADS-CASA CN235, C295
- A310 MRTT BEVS system & tail boom bearing and Rack supports
- IAI G250

## SPACE

- Hispasat
- Ariane 5
- ESA ATV
- Astrium W6A, W5A, Astra 5B, SES-6, AG1, Amazonas 3, Eutelsat 3B, Measat 3B,
- Technical assistance: inta, intespace, iabg
- Test procedures and reports

## DEFENCE

- A330 MRTT boom control unit and air refueling boom system simulation. ECS, oxygen, pneumatic and ice protection definition and qualification
- A400M landing gear Loads analysis
- Aircraft upgrades & pods
- Satellite tracking system
- Passive missiles and ac tracking system
- Thermoset based ballistic protection materials & developments
- Simulators
- Networks and comms vehicles integration

## NUCLEAR

- Mechanical engineering: Beams structures design works, 3D building scanners upgrade, main structures, modifications, Radioactive waste treatment center study
- Civil engineering: Offices and buildings improvements, Networks analysis, Topographical survey, Storage areas assessments
- PSBOOSTER
- ALICE
- LHC

## OTHERS

- Eolic, Parts design & manufacturing for Windmill to produce eolic energy
- Hydroelectric Pipelines
- Gas, Pressure container by sections for gases
- Thermal, Support turbine parts
- Railway
- Civil

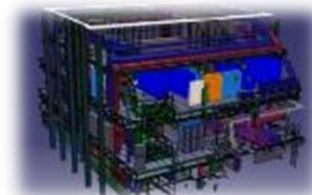
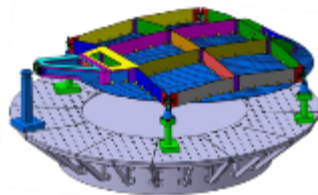
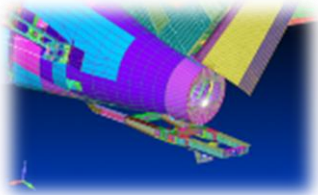

**AEROSERTEC**



# RESEARCH & DEVELOPMENT

## UNMANNED SYSTEMS

- Autogiro UAV piloted and equipped from factory with two cameras, one for ground viewing, the other for flight view, with a large bay for any other payload or sensor.
- Autopilot simulator software and flight simulator
- Unmanned Ground Vehicle (UGV) for detection of nuclear, biological and chemical threats (NBC). Versatile and ready



## AUTOMATION

- Support system to control of airport traffic.
- Precision assembly devices form manufacturing processes
- Portable Press Automated machine that produce every 12 seconds 2 bricks with 250x120x60 mm dimensions
- Synchronized line machine mixing products from two hoppers with cement, sand, water and additives

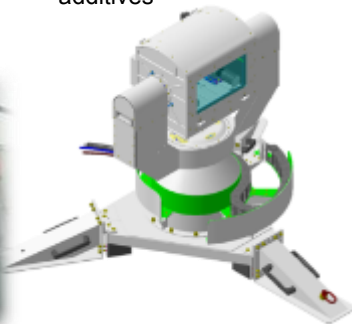

## VISION SYSTEMS

- Facilitate production tasks and specially the provision of information in aeronautic assembly processes
- Augmented reality glasses Laster MG1. LeapMotion Hand Detection
- Riveting inspection
- 3D Scanner. Human recognition by field depth to locate with respect other objects
- Plenoptic specific sensors
- Geographic information system (GIS)

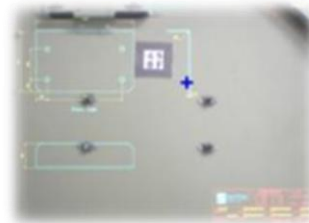

## ROBOTIC

- Support different aircraft equipment, with a robot perform various tasks such as placing ribs, tasks riveting or sealing.
- End Effectors tools interchangeable
- Sensitive clamp force
- Cameras and computer vision techniques

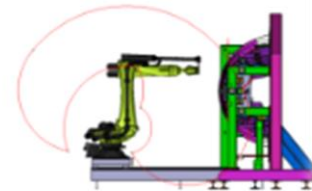

## MATERIALS

- PET recycled aeronautic applications
- Complex materials steel based for ballistic application

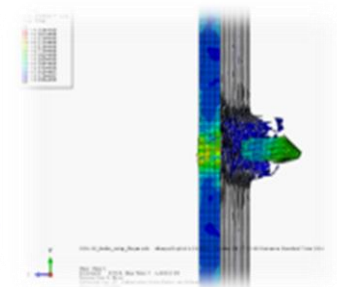

**AEROSERTEC**  
**CDTI**





## REFERENCE PROJECTS

# ENGINEERING

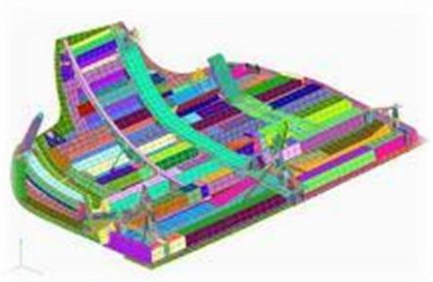

A-380 MAIN LANDING GEAR DOORS.

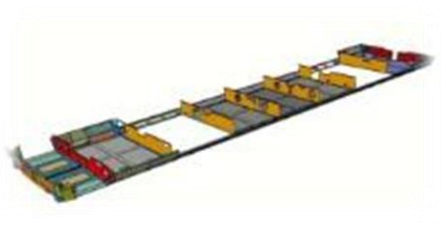

TALGO 350: UNDER CARRIAGES.

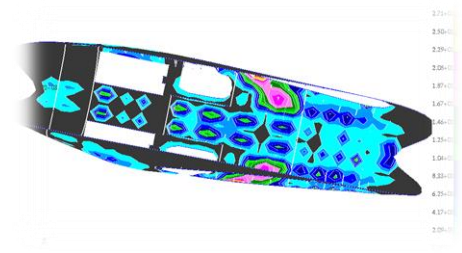

A380 BELLY FAIRING STRUCTURAL SIZING



AIR INLET DUCT (ATF) FOR TP400-D6 DEVELOPMENT ENGINE

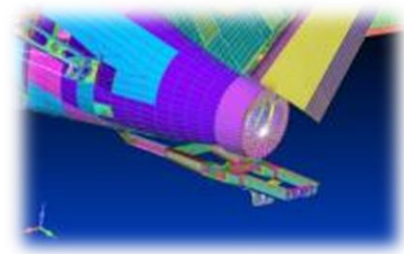

IAI G250 AFTER FUSELAGE-STALL RECOVERY SYSTEM



CERN-PSBOOSTER MODELIZATION OF THE RING-GANGWAY

# TEST BENCHES

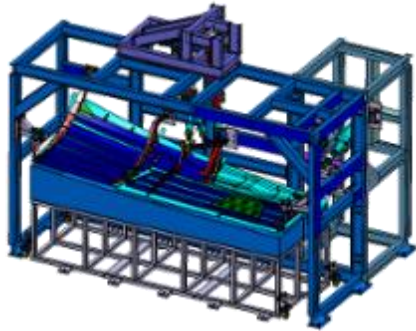

A-380 / WLGD & BLGD  
(INNER & OUTER) FULL  
SCALE & FATIGUE TEST

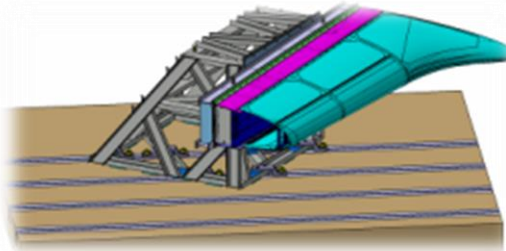

A-380 BIRD IMPACT  
TEST HTP LE



A400M GVT TEST RIG

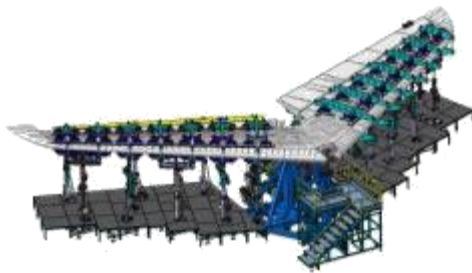

A400M FULL SCALE &  
FATIGUE TEST

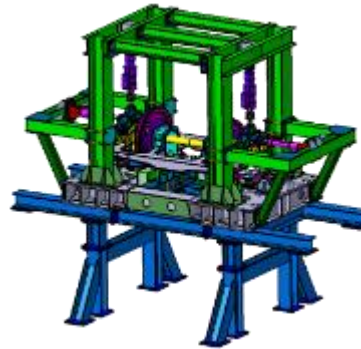

Talgo 350: BOGIES  
TEST BENCH



A350XW-BWLGD  
FULL SCALE &  
FATIGUE TEST

# TOOLING

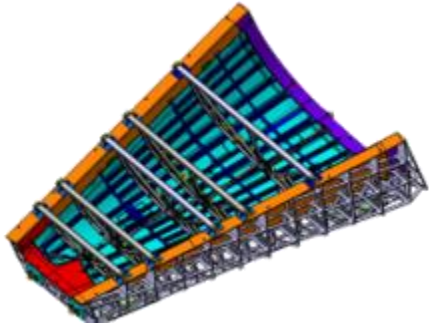

A380 SECTION 19.1  
MANUFACTURING  
AND ASSEMBLY  
TOOLING



TIGER HELICOPTER  
ASSEMBLY LINE MATING  
JIG

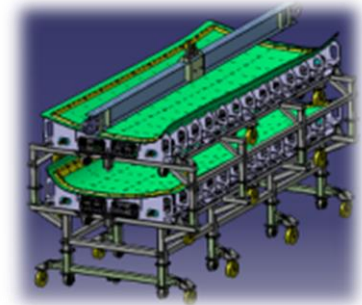

A-400M AUTOCLAVE  
MANUFACTURING TOOLING

**AEROSERTEC**



# SIMULATORS

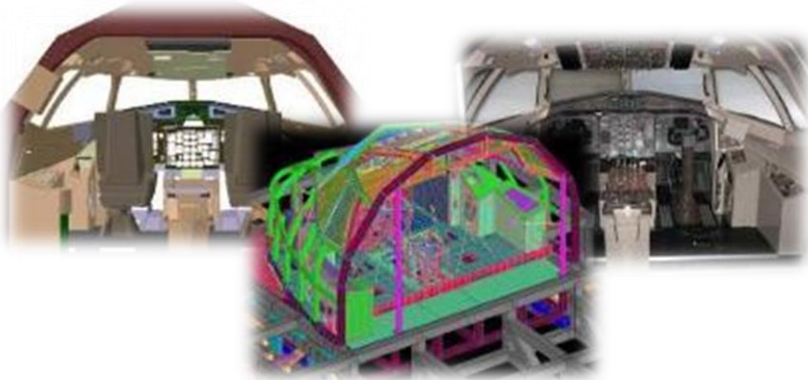

ATR 72-500 CIVIL AIRCRAFT  
FULL MISSION SIMULATOR LEVEL D

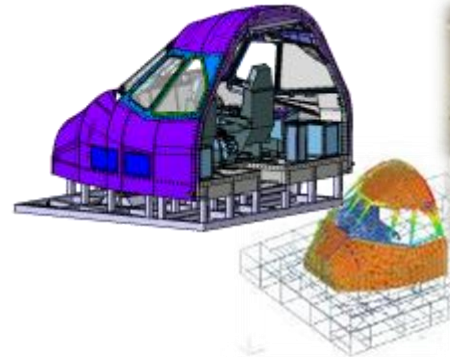

CN-235 MILITARY AIRCRAFT  
FULL MISSION SIMULATOR LEVEL D

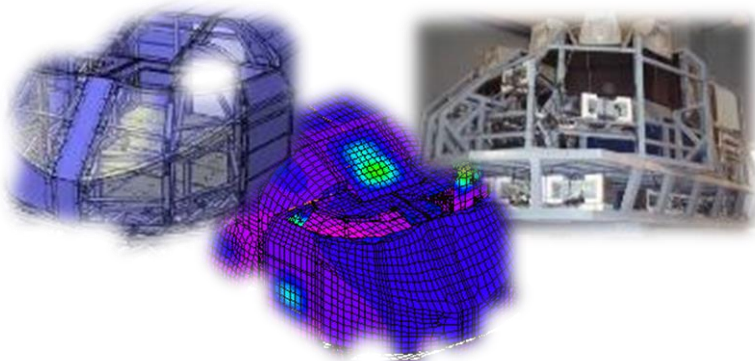

A-320 CIVIL AIRCRAFT  
FULL MISSION SIMULATOR, CLS

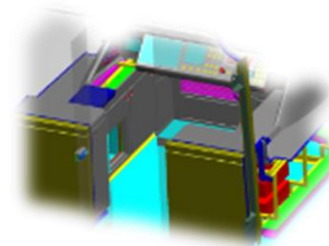

CAF  
BILBAO TRAM – DRIVING POST

**AEROSERTEC**

# TRACKING & TARGETING SYSTEMS

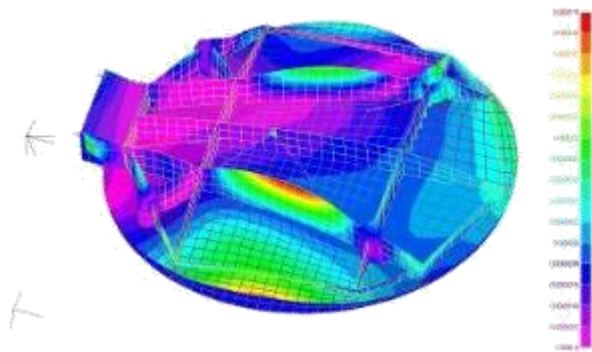

HISPASAT COMPOSITE MATERIAL

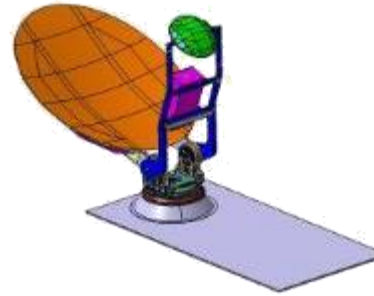

TRANSMISSION / RECEPTION SATELLITE TRACKING ANTENNAS. OVER-THE-ROAD MOBILE AND FIXED PLATFORM



SPANISH ARMY AIRCRAFT & MISSILE PASIVE TRACKING SYSTEM

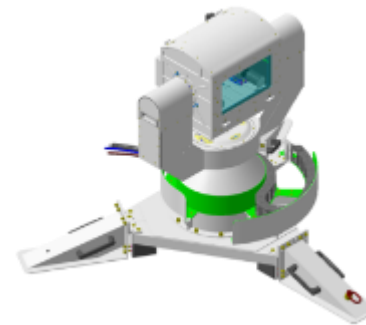

SUPPORT SYSTEM TO CONTROL OF AIRPORT TRAFFIC.

**AEROSERTEC**



# SOFTWARE DEVELOPMENT

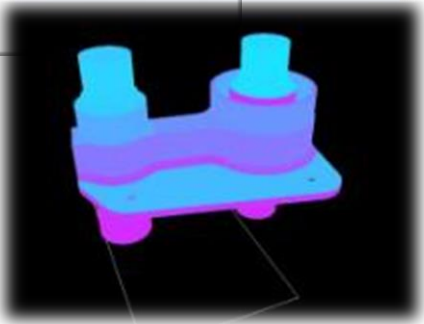
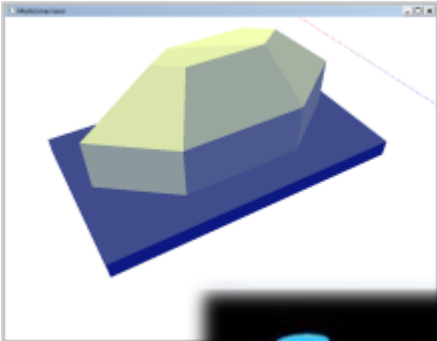

Metrology software and simulators.

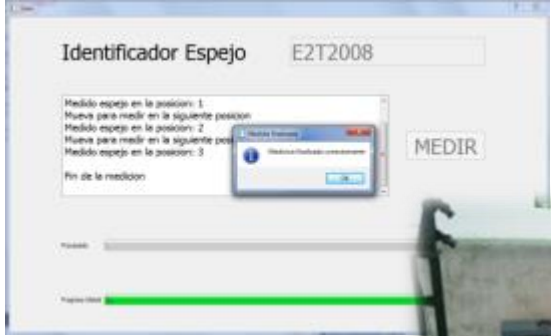

Industrial software

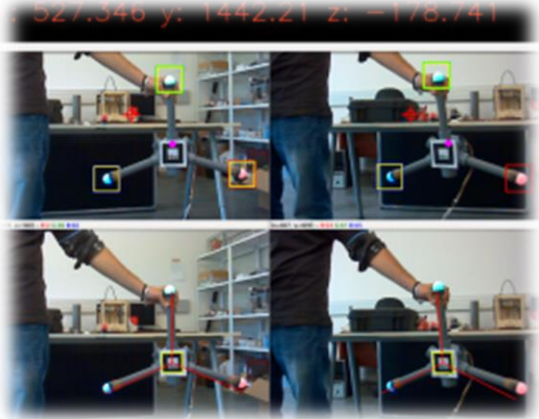

Tracking technologies, AR, VR, CV

# MAIN CUSTOMERS





# ASCENT PROJECT

## Active Simulator Cockpit Enhancement



El objetivo es desarrollar un Simulador de Cabina Activa integrando una Ground Station mejorada y avanzada para crear un nuevo Concepto de Operación de Aeronave Regional. Permitirá la realización de la validación de factores humanos, reduciendo la de carga de trabajo de los pilotos en un entorno de prueba de nueva generación de simuladores.

El objetivo de este proyecto ASCENT es la integración de nuevas funcionalidades dentro un simulador de cabina de vuelo que se ubicará en las instalaciones de Airbus D&S

Los aspectos clave de la innovación se corresponden con:

Desarrollo de un entorno de prueba en el exterior de la cabina tanto diurno como nocturno.

Desarrollo de paneles de instrumentos mejorados y de los controles de vuelo.

Desarrollo de un sistema de monitorización de los pilotos por medio de un sistema de sensores capaces de obtener datos biológicos y medir niveles de stress.

Desarrollo de un entorno de sonido 3D innovador.

Integración de la tecnología Li Fi en simuladores de aeronaves. Demostrador Li Fi.

Desarrollo de una Groun Station innovadora, incluyendo modelos de simulación de enlace de datos (Data Link simulation models )

**AEROSERTEC**



# ASCENT PROJECT

## Active Simulator Cockpit Enhancement



### Integration of the Li Fi Technology in Aircraft Simulators.

Uno de los nuevos desarrollos potenciales que se incluirán en la futura cabina de aeronave será el uso intensivo de sistemas de comunicación inalámbrica. Con el fin de probar eficazmente este nuevo potencial de uso de la tecnología, el simulador estará preparado para crear las interferencias necesarias para probar cada dispositivo independiente.

Una vez que se reproduce el entorno real de la cabina, se pueden probar diferentes tecnologías de comunicación inalámbrica.

El objetivo de esta parte del proyecto es probar la integración de la tecnología de comunicación Li Fi en una cabina de aeronave mediante un simulador.

El uso de simuladores para validar las nuevas tecnologías que se implementarán en futuros avances de aviones en este caso toma especial relevancia ya que las tareas a realizar en el simulador serán similares y fáciles de transferir a aviones reales.

El proyecto se centrará en las tareas de actualización, chequeo y el mantenimiento de los sistemas de cabina, una tarea que suele consumir mucho tiempo y se realiza en un entorno restringido de RF.

El uso de la tecnología Li Fi reducirá drásticamente el tiempo de operación.

**AEROSERTEC**

# ASCENT PROJECT

## Active Simulator Cockpit Enhancement

### Ventajas del Li Fi sobre el Wi Fi.

- Li Fi utiliza señales de luz en lugar de señales de radio frecuencia, por lo que son inmunes a perturbaciones.

- Li Fi podría utilizarse con seguridad en aeronaves sin afectar las señales de las aerolíneas.

- Integrado en los dispositivos médicos y en los hospitales, ya que esta tecnología no se trata de ondas de radio, por lo que se puede utilizar fácilmente en todos los lugares donde Bluetooth, infrarrojos, Wi-Fi e Internet son ampliamente en uso.

- Bajo el agua en el mar Wi-Fi no funciona en absoluto, pero la luz se puede utilizar y por lo tanto exploraciones submarinas sería más indicado.

- Hay miles de millones de bombillas en todo el mundo que sólo necesitan ser reemplazados con LED's para transmitir datos.

- La seguridad es un beneficio colateral de la utilización de la luz para la transferencia de datos, ya que no penetra a través de las paredes.

- En las autopistas para aplicaciones de control de tráfico como donde los coches pueden tener faros basados en LED, retroiluminación LED, y pueden comunicarse entre sí y evitar accidentes. El uso de esta tecnología en todo el mundo cada farola sería un punto de acceso gratuito a los datos.

- Los problemas de la escasez de ancho de banda de radiofrecuencia pueden ser solucionados por Li-Fi

- Li Fi aparece como una nueva alternativa más ecológica, saludable y barata al WiFi.

### Limitaciones del Li Fi.

El problema es que la luz no puede pasar a través de los objetos, por lo que si el receptor es inadvertidamente bloqueado de cualquier manera, entonces la señal se cortará inmediatamente.

Interferencia de fuentes de luz externas como la luz solar, bombillas normales; Y los materiales opacos en el camino de transmisión causarán interrupción en la comunicación.

El alto costo de instalación de los sistemas VLC puede ser complementado con la implementación a gran escala de VLC, aunque la adopción de la tecnología VLC reducirá los costos operativos adicionales como los cargos de electricidad, los gastos de mantenimiento, etc.



# ASCENT PROJECT



## Active Simulator Cockpit Enhancement

### Li Fi Demonstrator.

El primer paso serán pruebas individuales de cada uno de los dispositivos, estas pruebas serán realizadas mediante test de emisión-recepción donde podemos comprobar la calidad de la señal recibida contra la enviada. Esta fase nos permitirá entender el comportamiento de cada dispositivo en un entorno de cockpit real y cómo afecta al rendimiento del dispositivo inalámbrico.

El proceso para desarrollar esta capacidad será:

1) **Arquitectura del sistema.** El primer enfoque es conectar una conexión Li Fi al puerto del FMS para demostrar que un sistema estándar de gestión de vuelos pueda ser conectado por Li Fi. Este sistema tendrá al menos 3 sistemas potenciales conectados. 3 computadoras del paquete del vuelo.

2) **Diferentes distribuciones de equipos.** Li Fi no necesita la línea de visión, ya que puede utilizar las reflexiones para conectar dispositivos, pero el proyecto comprobará la mejor posición para asignar el emisor y el receptor en la cabina para que pueda comunicarse con el piloto y el copiloto y con el personal de tierra en los alrededores.

3) **Prueba de enlace de datos.** Probar la velocidad y cantidad de información que podremos controlar en tiempo real y sus potenciales retrasos y sus causas, problemas y soluciones.

El **resultado** de esto debe ser un control completo de todos los parámetros de simulación de la cabina por medio de este protocolo.

La **decisión final** sobre esta prueba en vuelo dependerá de la madurez alcanzada en el nivel de simulador alcanzado por el proyecto.



# Thank You

## Contact Information

David de la Casa Carrera

[david.delacasa@sertec.net](mailto:david.delacasa@sertec.net)

+34 917241775

## Follow Us:



[www.sertec.net](http://www.sertec.net)



<https://twitter.com/itsertec>



<https://www.linkedin.com/company/sertec>



<https://www.youtube.com/channel/UCdsP5wDhgyFPkxkna2-SGMw>



[www.facebook.com/sertecengineering?fref=ts](http://www.facebook.com/sertecengineering?fref=ts)

**AEROSERTEC**