

Instrumentación optoelectrónica para ensayos y monitorización

José A. García Souto
**Workshop: Aplicaciones de la luz en la
industria aeroespacial**

Optoelectronic Instrumentation for testing and monitoring

Fiber Optic Sensors /
Optical systems

Novel Optical Sources

Fast Multi-channel
Instrumentation Systems

Demonstrators relevant to
aerospace industry

Optoelectronic Instrumentation for testing and monitoring

Fiber Optic Sensors /
Optical systems

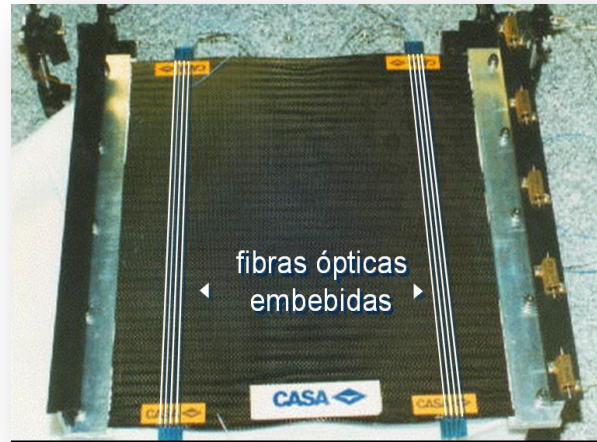

JSTQE (2000)



Sensors (2016)

SMF embedded in composite

FBG sensors (dynamic)

FO sensor of ultrasound AE

Non-contact / FO sensor of
vibrations (harsh-env.)

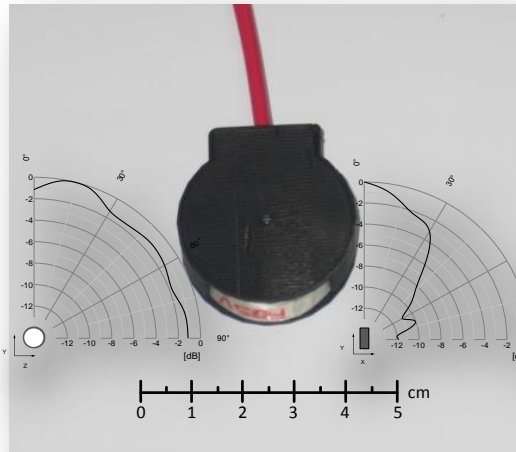

Sensors (2012)



OLE (2017)

Optoelectronic Instrumentation for testing and monitoring

Diode lasers DFB, DM, VCSEL

Tunable lasers

Photonic local oscillators

Optical Frequency Combs

Novel Optical Sources

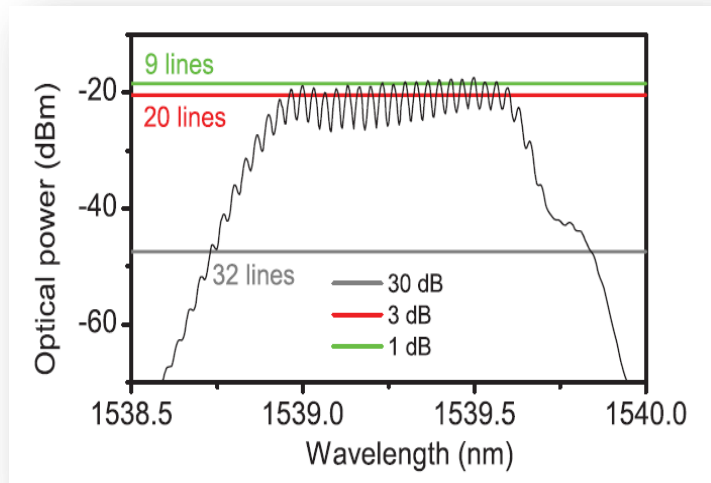

PTL (2013)

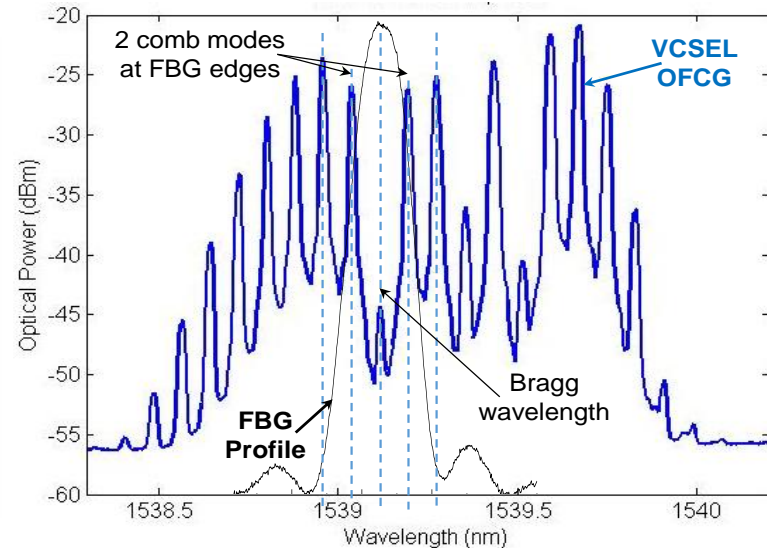

OFS (2017)

Optoelectronic Instrumentation for testing and monitoring

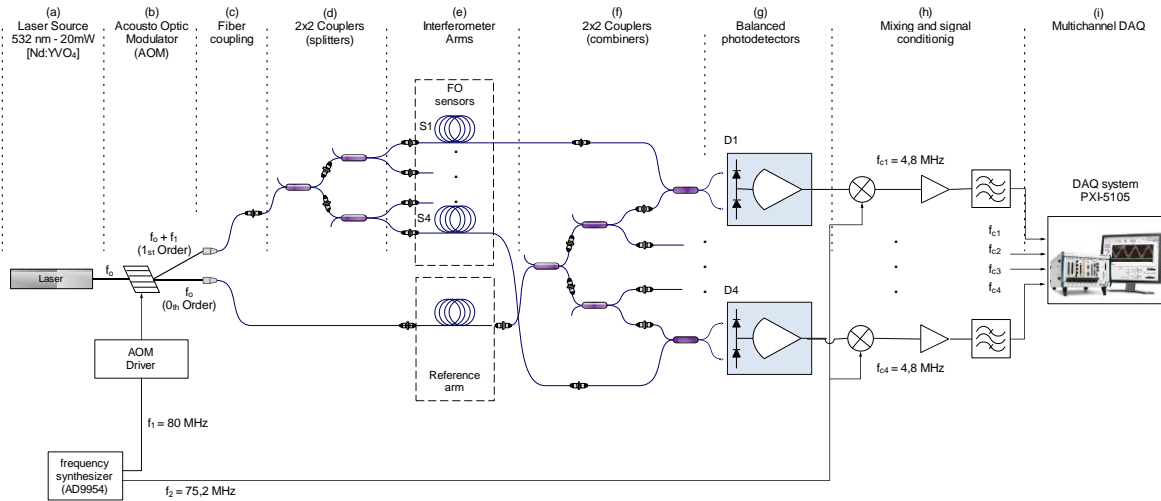

Fast multi-channel interferometric systems

Fast multi-channel ADQ and signal processing

Parallel read-out of FBG

Fast Multi-channel Instrumentation Systems

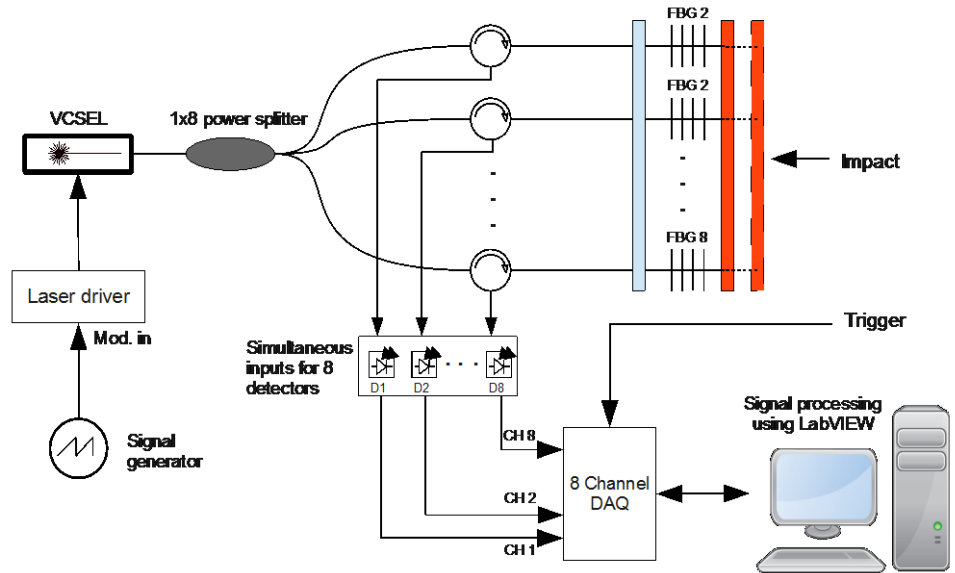

Optoelectronic Instrumentation for testing and monitoring

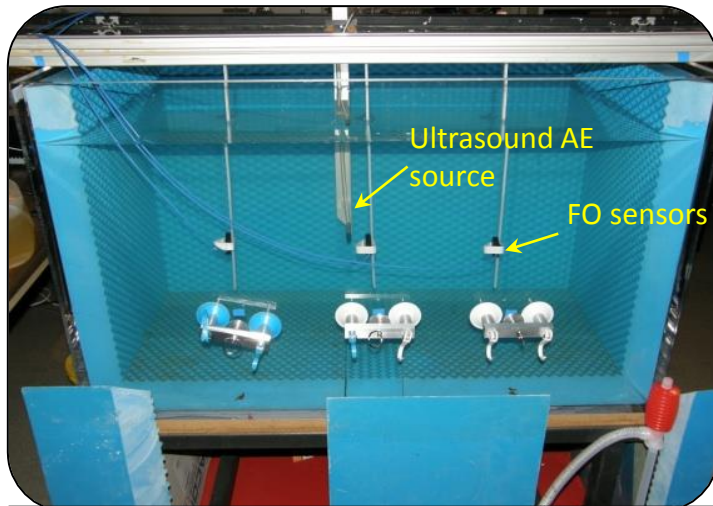

Ultrasound / Acoustic Emission

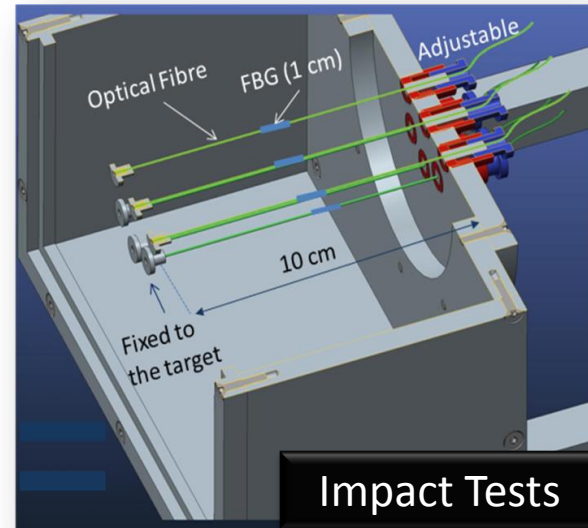

Impact Tests

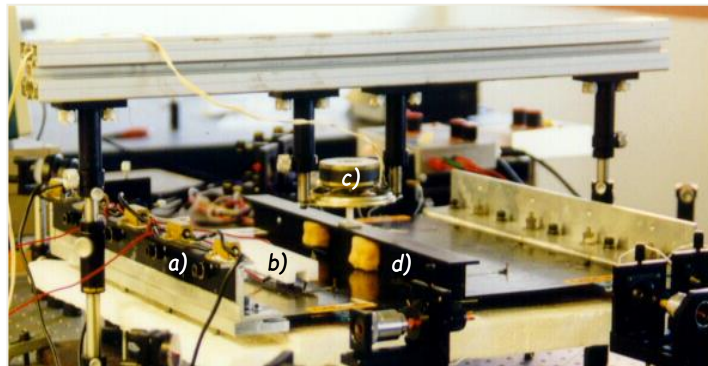

Temperature / Strain / Vibrations

Demonstrators relevant to Aeronautical Industry

Projects: Fast non-contact optical monitoring of hypervelocity impacts on composite materials

Hypervelocity impacts in the Light Gas Gun



Ballistic Testing Laboratory at UC3M

Projects: remote ice-salt-water detection / gas sensing

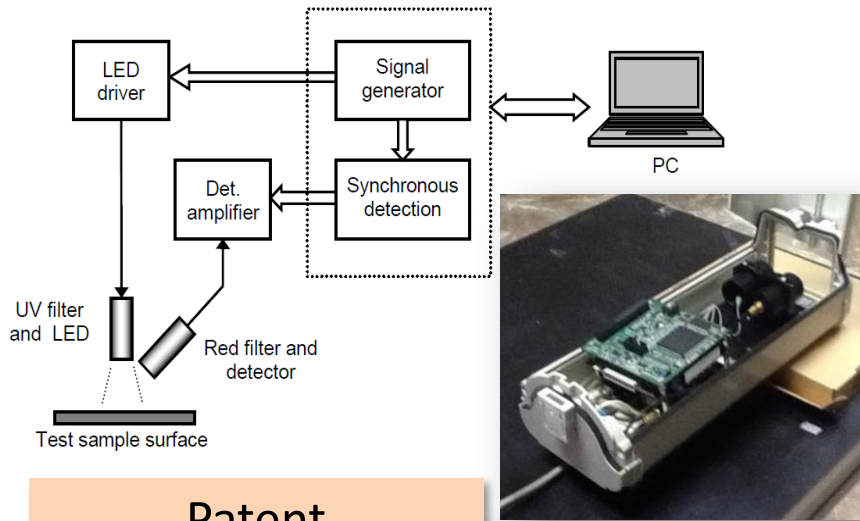

Patent

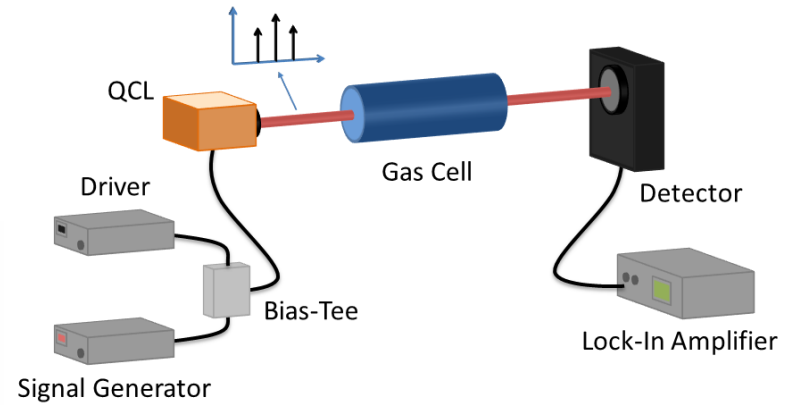

Remote sensing / satellite payload

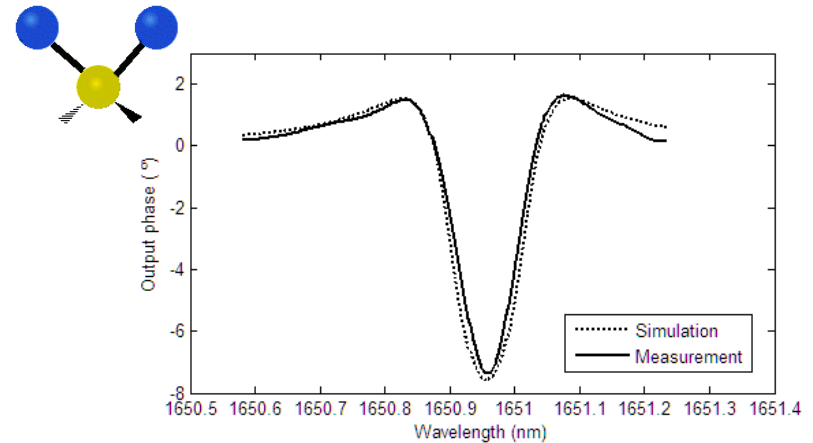

Projects: optical fiber data transmission in aeronautical environments

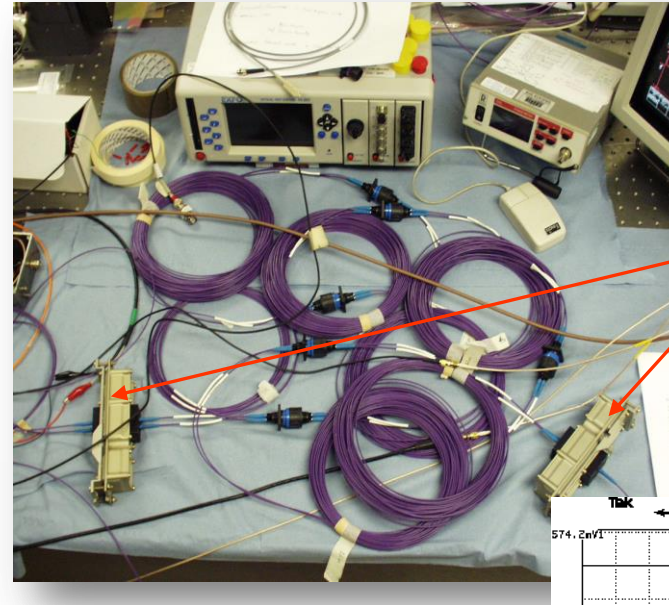
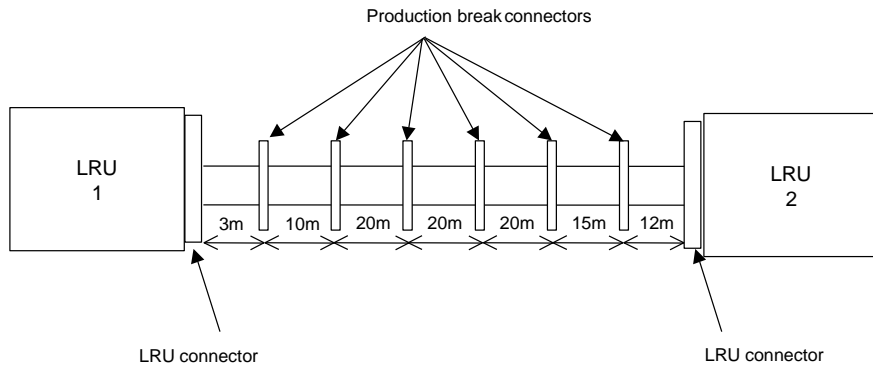

ARINC input/output connectors

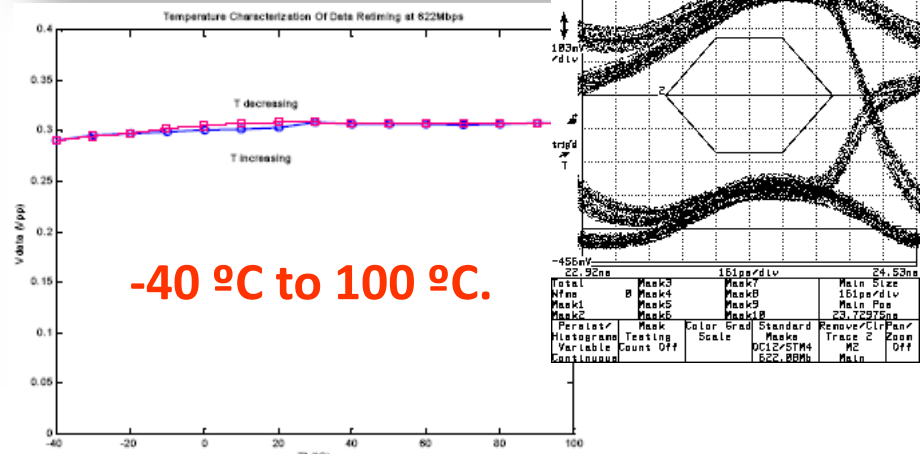
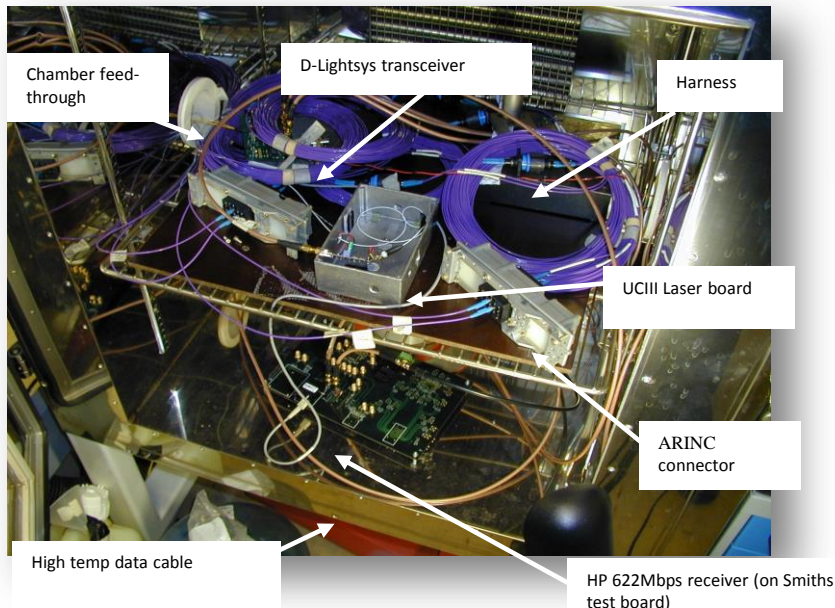

Projects: radio over fiber signal distribution

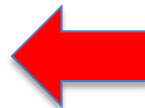
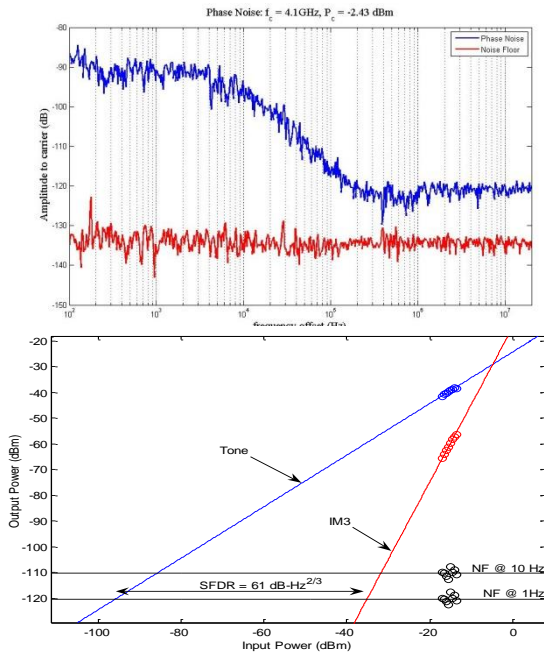
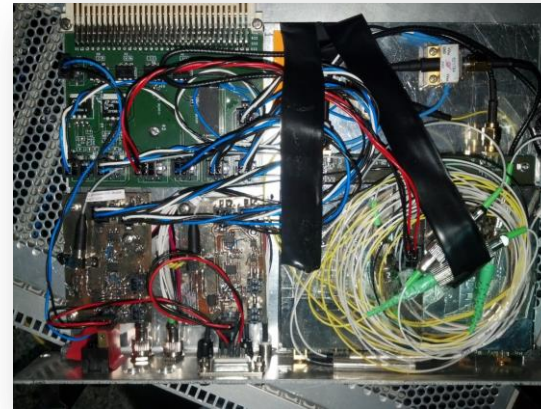
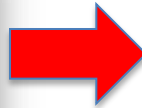
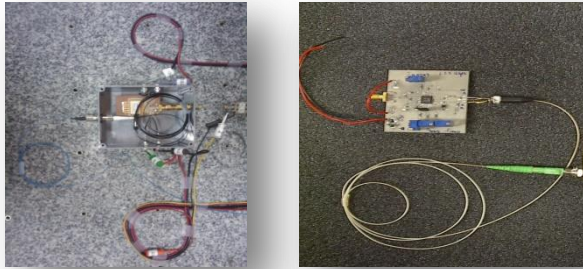

Projects: air to air refueling & UAV refueling (AIRBUS D&S)

DOFC Implementation

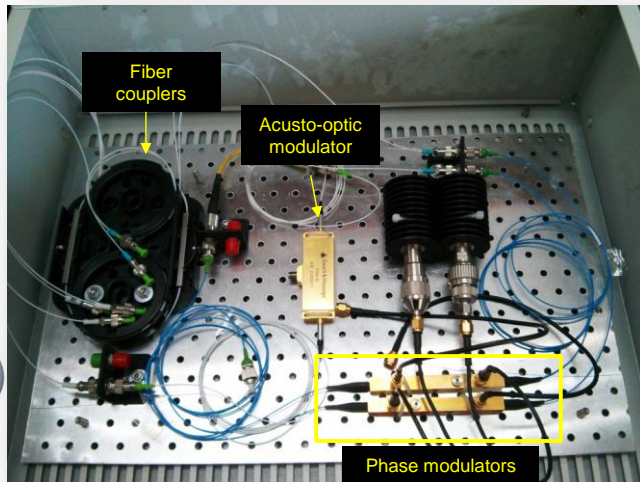

Patent: “Method and system for determining a relative position to a target”
 N° de solicitud: 15382230.9 – 1812
 Fecha de prioridad: 5 Mayo 2015
 Entidad titular: Airbus Defence and Space, S.A.U.

‘FEASIBILITY OF A PRECISE GUIDANCE SYSTEM FOR RECEIVERS AIRCRAFTS FOR AAR OPERATIONS, TAE-T-NT-140006’
 Contractor: **AIRBUS Defence and Space.**

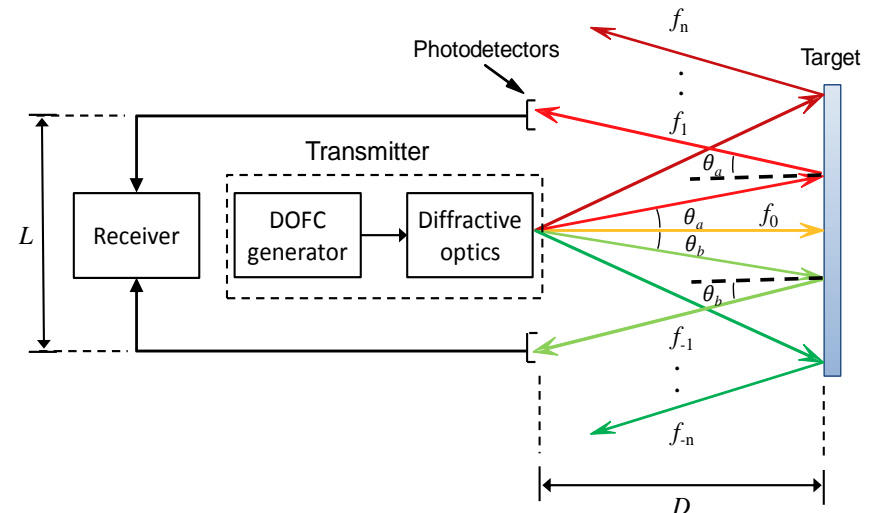

Projects: Free Space Optical Communications

‘AOC-Airbone Terminal Demonstrator-Workpackage for second demo’
Contractor: **AIRBUS Defence and Space Optronics GmbH.**

Projects: Drone guidance, positioning and precision landing

‘Guidance based on Laser technologies for positioning in two axes (PO E8237806K)’
Contractor: **AIRBUS Defence and Space.**

José A. García Souto
jsouto@ing.uc3m.es