



7 May 2019

*Tres Cantos, Madrid,
Spain*



Advanced Imaging S.L.

Custom CMOS Image Sensors: for earth observation and space

Renato Turchetta (CEO)

renato.turchetta@imasenic.com

Barcelona, Spain

The company

- Young, dynamic, innovation-led company
- Design of custom CMOS image sensors (CIS)
- Teams from scientific/medical and consumer markets
- Experienced in designing for demanding performance
- Partnering with leading technology companies around the world to provide optimized supply chain

imasenic 

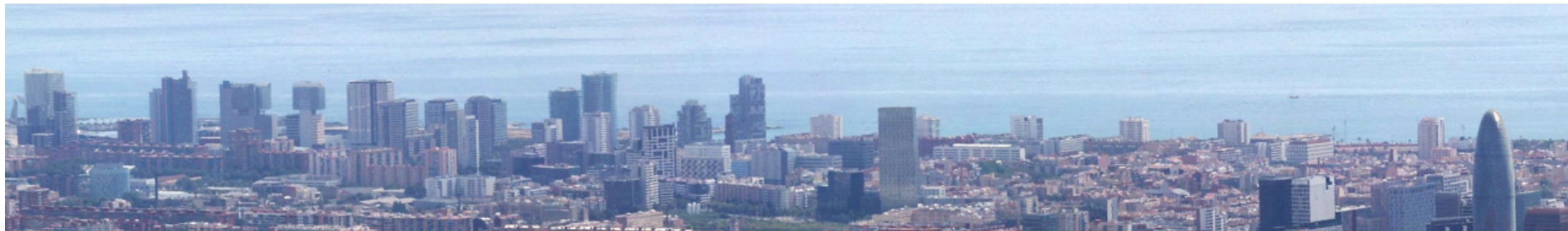

Our offering

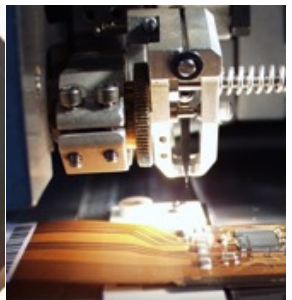
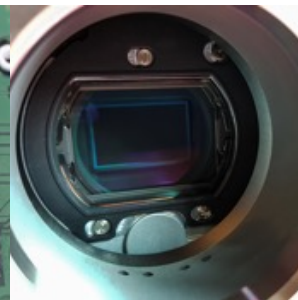
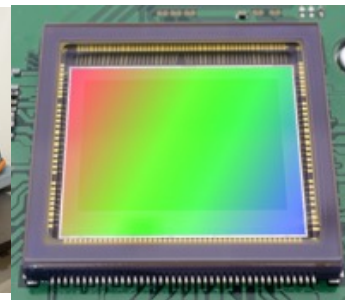
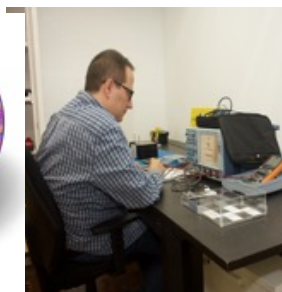
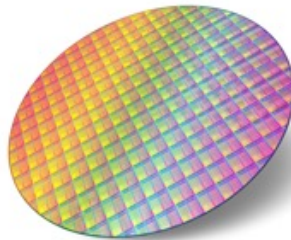
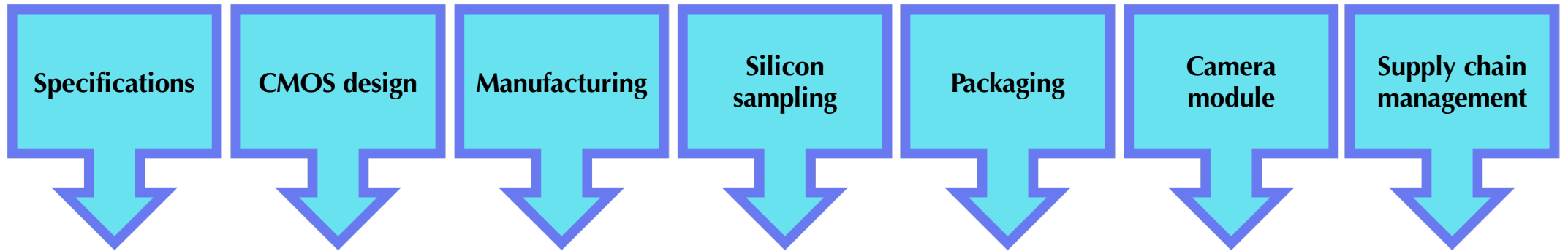

Applications



MEDICINE

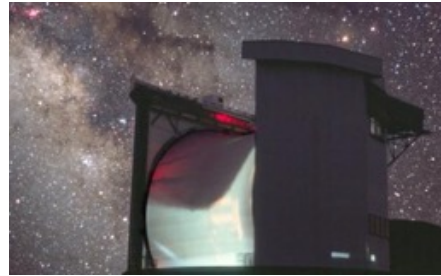

SCIENCE

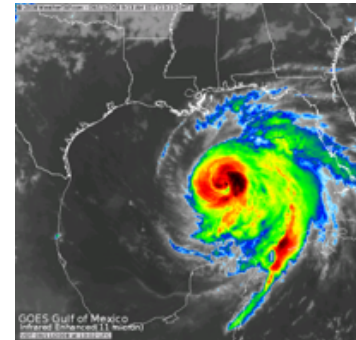

**EARTH
OBSERVATION**

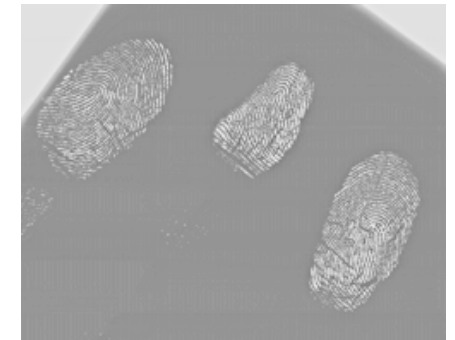

SECURITY

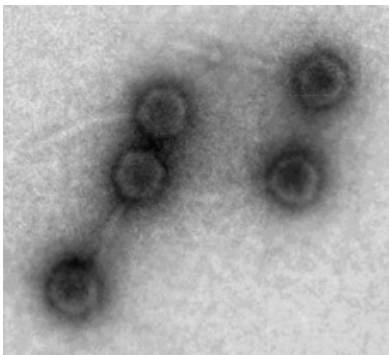

BIOLOGY



**SPACE /
AERONAUTICS**



INDUSTRIAL



AUTOMOTIVE

Visible light and beyond ...



... and particle detection

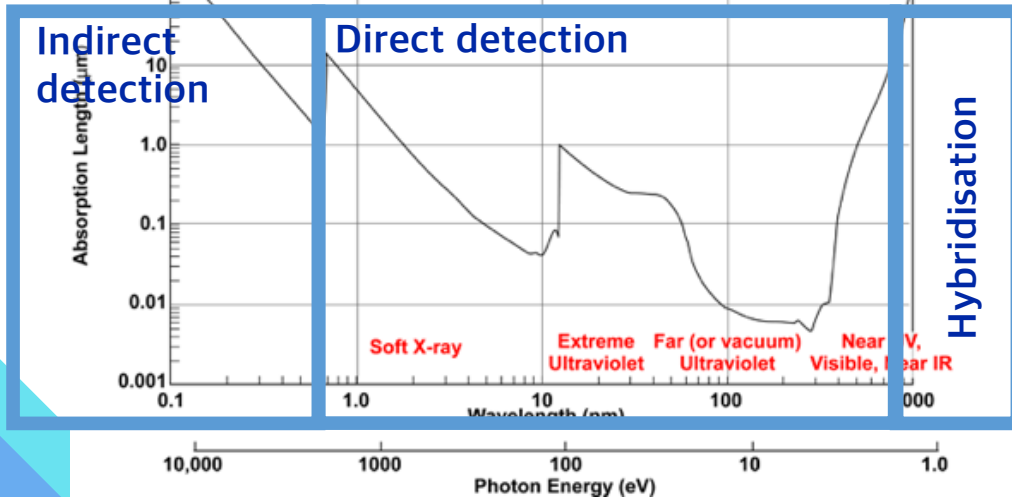
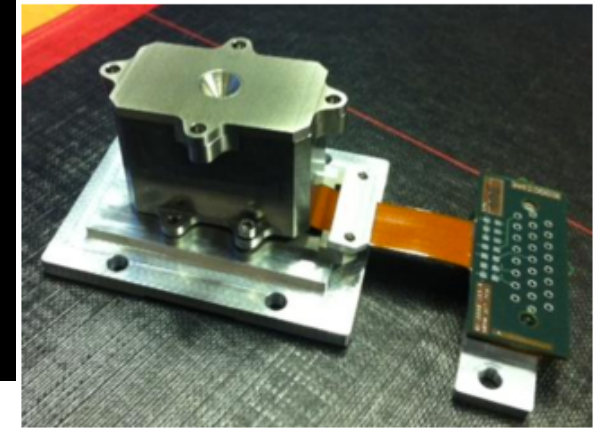
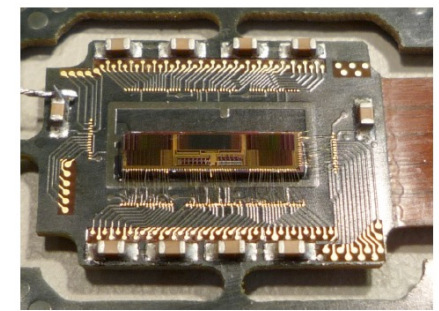
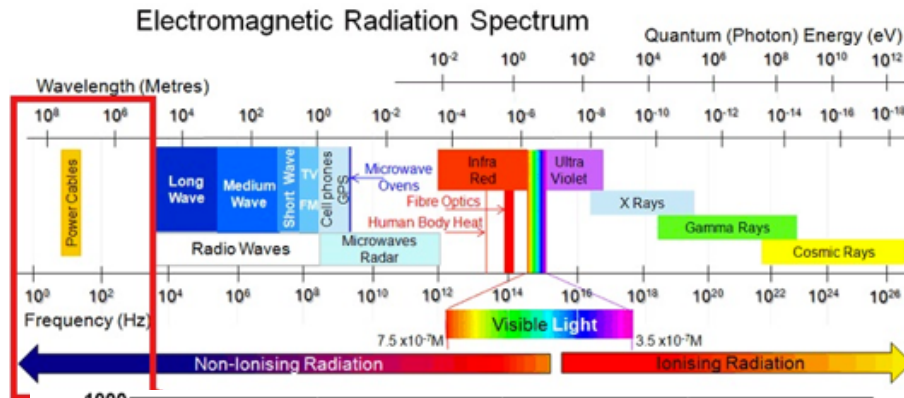

Camera-on-a-chip

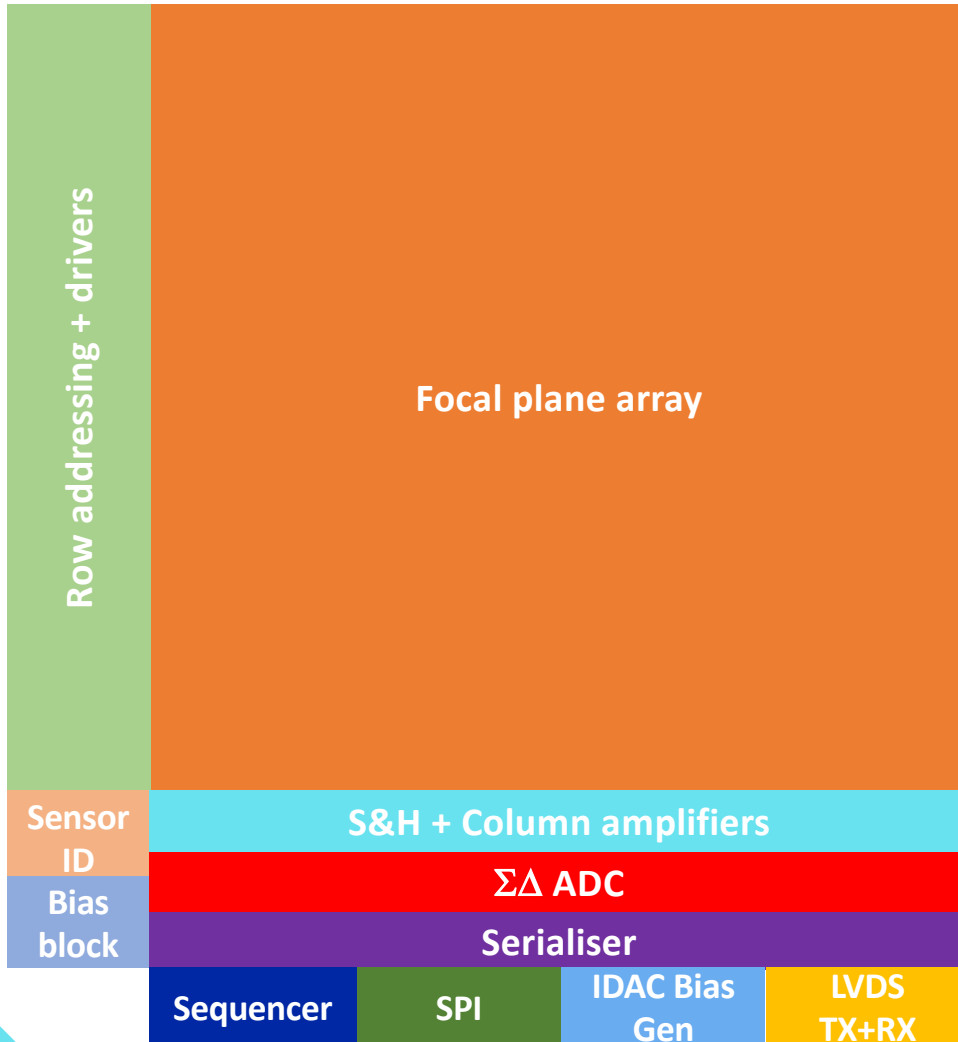

Custom pixels

Low power ADC

High speed serialisers

On-chip programming

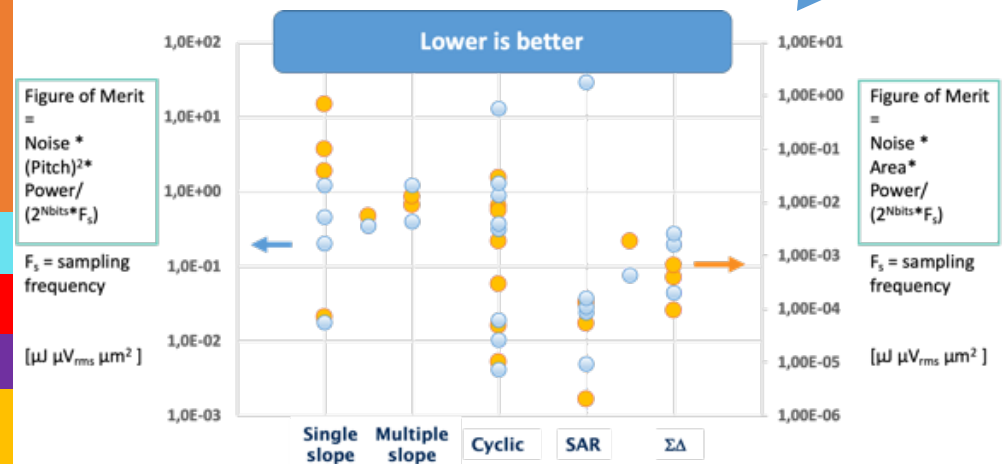

Sensing options.

- Manufacturing in advanced CIS technology down to 65 nm
- *Large sensors up to* wafer-scale sensors, on 200 and 300 mm diameter wafers
- Rolling shutter (down to 1.12 μm) and global shutter (down to 3.2 μm) pixels
- Back-side illumination (BSI) for high quantum efficiency
- Low noise: 1 e- rms
- High Dynamic Range (HDR) pixels: lateral overflow \rightarrow 20 bits linear
- *Radiation-hard sensors*
- *High speed sensors*
- *Hyperactive pixel*
- *3D sensing*

Large format sensors

- Wafer-scale (200 and 300 mm diameter)
- Design optimised for high yield

Video rate,
wafer-
scale,
14cm x
24cm

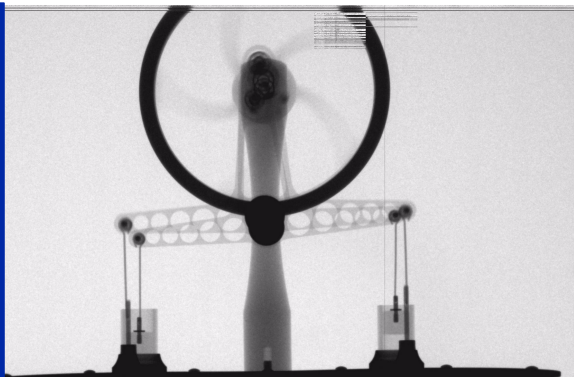

Courtesy of Rutherford Appleton Laboratory

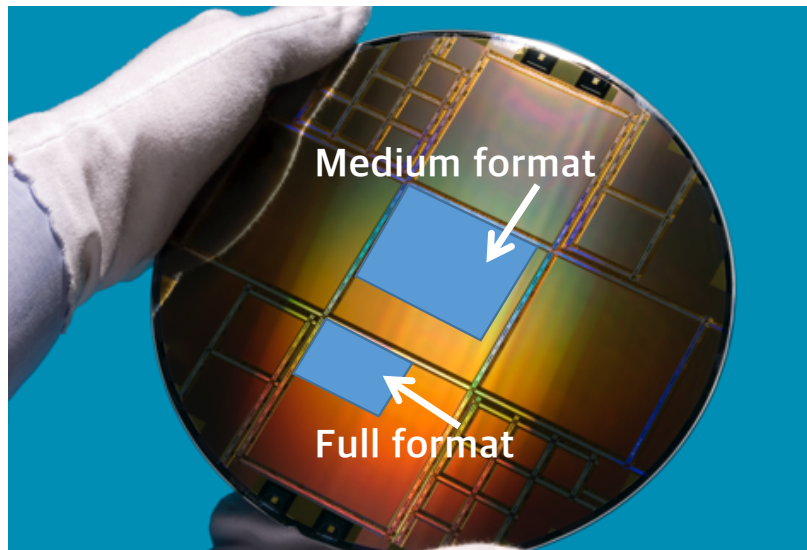

- High speed, low power:
video rate on
12cmx12cm, 6.7 Mpixel
sensor

imasenic 



- 16 Mpixels
video rate,
6cmx6cm size

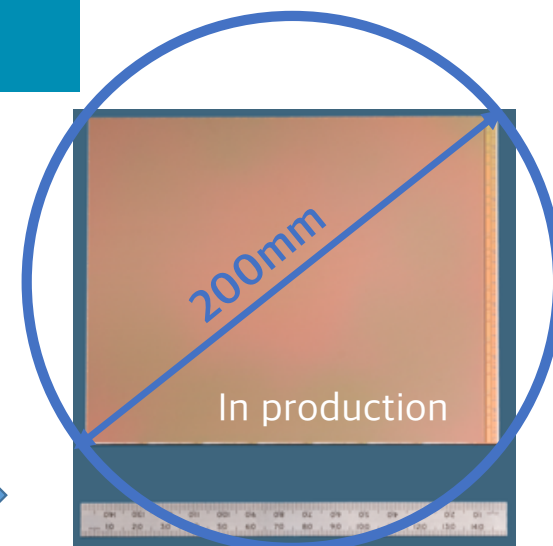

Radiation hard design

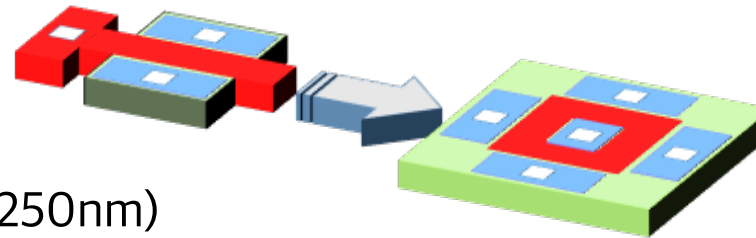

- Total dose resistance
 - Deep submicron technologies (<250nm)
 - Radiation hardening by design
- Single Event Upset (SEU)
 - Triple voting system
 - Design for latch-up prevention

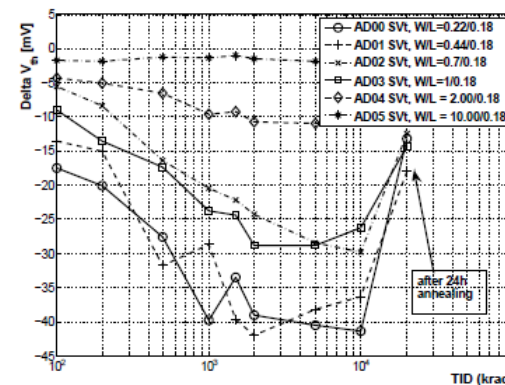
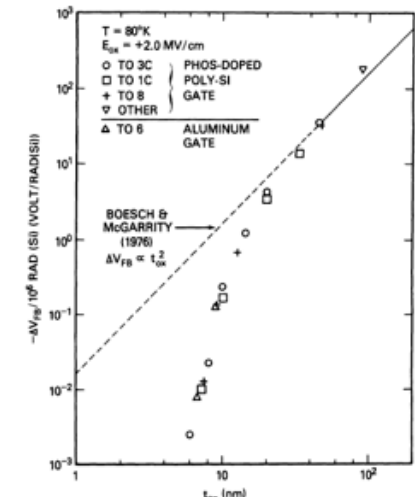

(a) NMOS transistors with various gate widths and a minimal gate length of 0.18 μm

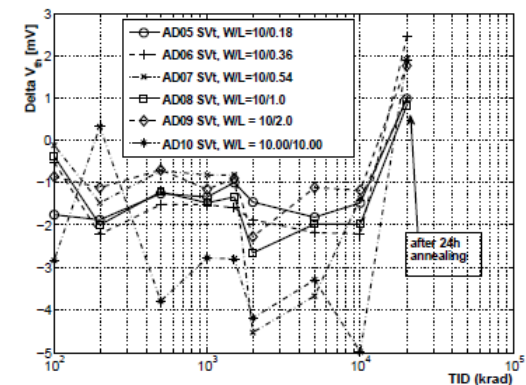

(b) NMOS transistors with various gate length and a fixed gate width of 10 μm

Fast and ultra-fast, high-resolution sensors

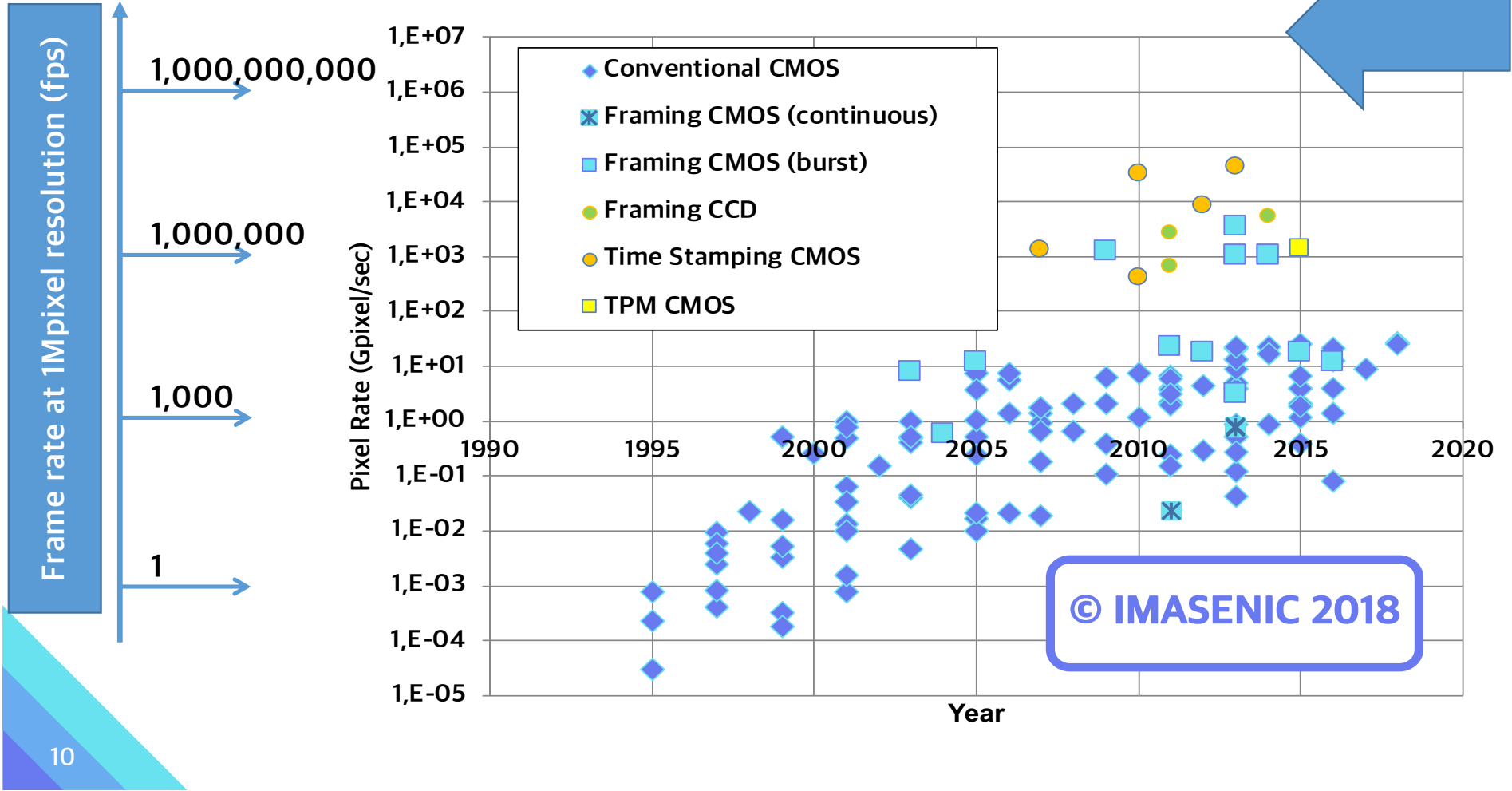

3D imaging



- Single Photon Avalanche Detectors → Direct Time-of-Flight (TOF)
- Ultra-high speed sensors → millions fps at Mpixel res.
- Pixel wise coded aperture
- Time pixel multiplexing

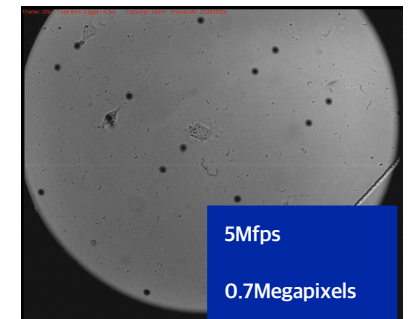
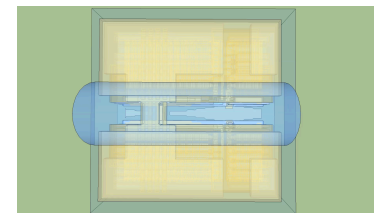
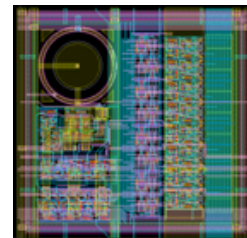
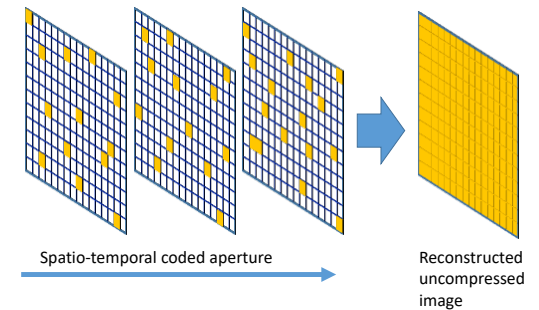
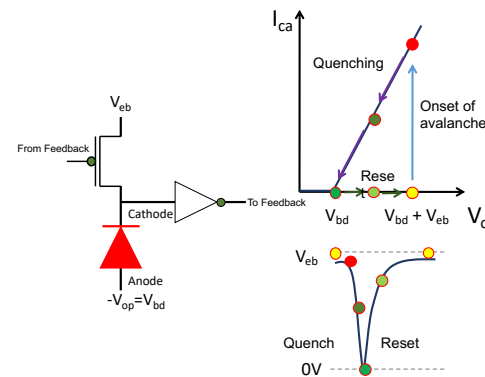
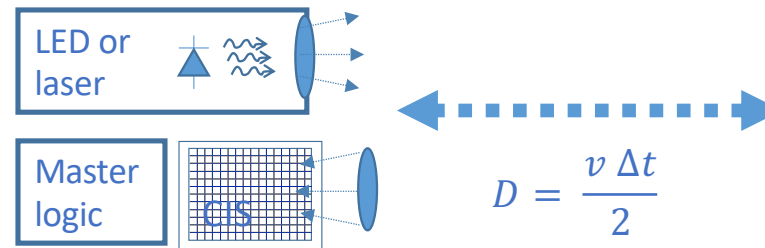

Hyperactive (smart) sensors



- Add functionality into focal plane to the pixel: e.g. feature extraction, neuromorphic vision, timing option
- High transistor count
- BSI technology and stacked technology enable high performance smart sensors

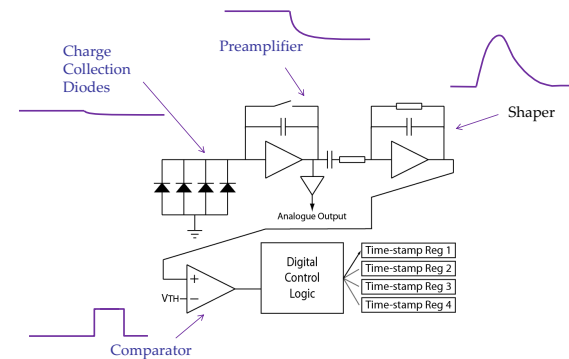

- 80MHz, flash-detecting sensor

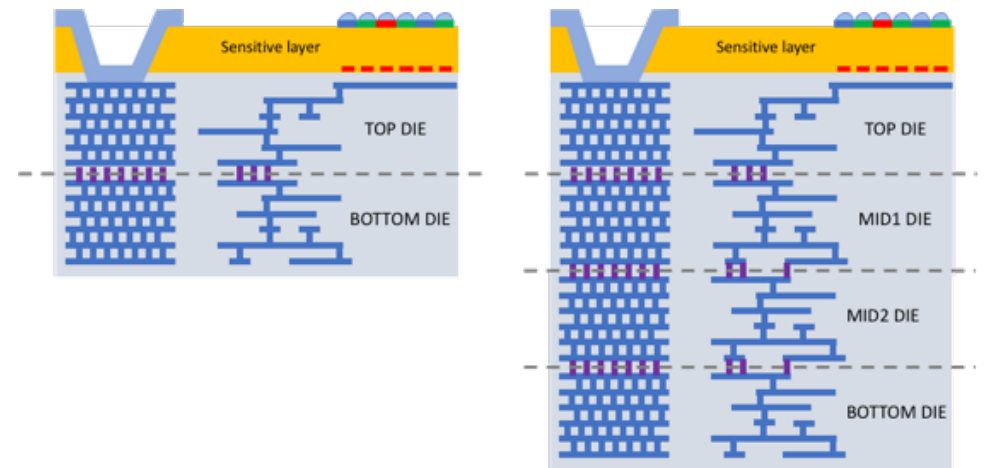

Conclusion

- IMASENIC is a growing company, fueled by innovation
- We offer sensor solutions for a diverse range of imaging applications
- 1st-time right design to shorten time-to-market
- We help customers to differentiate their product
- Wide range of solutions: come and talk to us with your ideas / needs

Thank you!

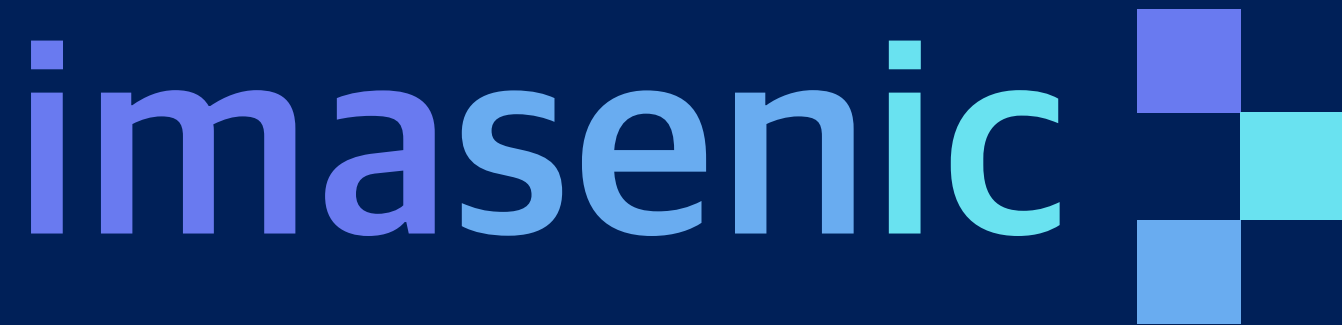

Your next CMOS imaging solution

www.imasenic.com